



TAKING EC LIVING TO SKY LIMITS

Where sky-high aspirations are worth living up to

Live up to your home pursuits with the first executive condominium in Sembawang. Nine skyscraping towers ringed by shimmering water bodies. 506 covetable units crowned by a sprawling SkyPark in their midst. Welcome home to SkyPark Residences.



THE EC WITH A WEALTH OF WATER FACILITIES

Where life is drenched with fun

Be surrounded by extensive water bodies in the forms of aquatic-themed facilities and landscaped pools. Over 30% of the ground-level communal spaces are filled with sparkling water bodies, promising a wealth of water leisure options and rippling views.



THE EC WITH AN ICONIC SKYPARK

Where lifestyles are taken to new heights

At more than 15 storeys above ground, experience a morning stretch among the clouds or candlelight moments under the stars. A breathtaking range of facilities that will take you to a new level of recreation. Atop the SkyPark, Singapore's northern panorama simply dazzles.

Travel around with ease

1-min drive to
Sembawang
Shopping Centre

2-min drive
to future
North-South
Expressway

3-min walk to
future Sports &
Recreation Hub

3-min drive to
SLE/CTE/TPE

5-min walk to
Sembawang
MRT Station

10-min drive
to Woodlands
Waterfront

5-min walk to
Sun Plaza and
Canberra Park
Connector

10-min drive to
Woodlands
Checkpoint

JOHOR (MALAYSIA)

Sky PARK

RESIDENCES

A PREFERRED ADDRESS

Where a network of conveniences resides

A highly developed estate in Singapore's northern tip, Sembawang has an established network of transportation, educational and shopping amenities. Strategically straddling the upcoming Woodlands Regional Centre and Punggol eco-town, this is where the promise of future lives.

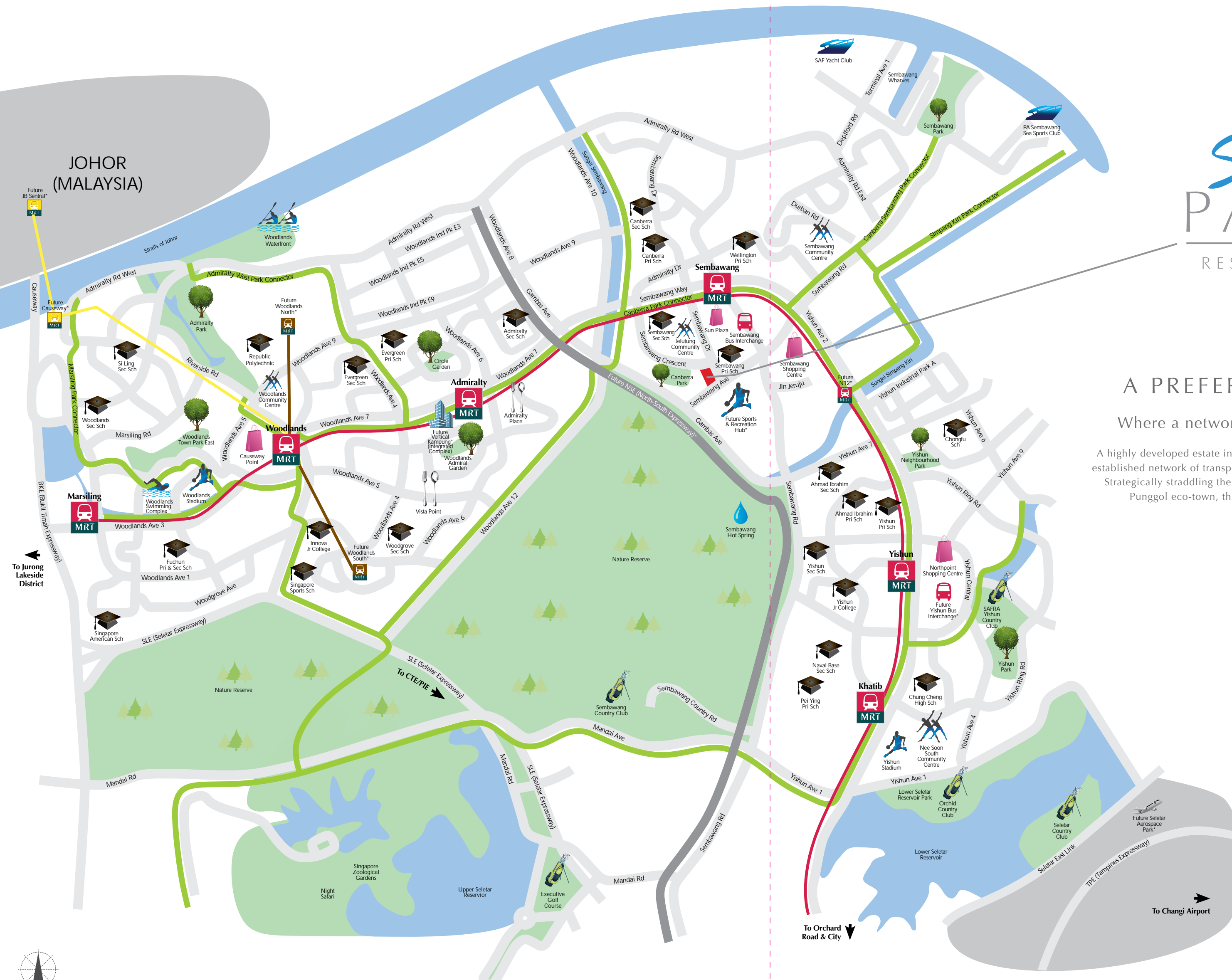

To Orchard Road & City

To Changi Airport

THE RUSTIC-YET-URBAN CHARMS



Canberra Park

Where the best of both worlds beckons

Cradled between lush greenery and urban amenities, you will get to live where the best of urbanity and nature resides. With the Sembawang MRT Station and the SLE/CTE/TPE in the immediate periphery, you can reach all parts of the island with ease.



Sembawang Park



Sembawang Primary School



Sembawang Shopping Centre



Sembawang MRT Station

A REGION OF BRIGHT PROSPECTS

Future North-South Expressway



Brand New Woodlands Regional Centre



Future Thomson MRT Line



Future Sports & Recreation Hub



Future Seletar Aerospace Park

Where more can be expected

With the upcoming Thomson MRT Line and North-South Expressway boosting connectivity between Sembawang and islandwide, as well as the Sports & Recreation Hub and Seletar Aerospace Park creating more lifestyle avenues, the future of Sembawang holds great promise.

A home to exceptional recreational lifestyles

50-Metre
Lap Pool

Pool Dining
Pods

100-Metre
SkyPark

Children's
Play Pool

Tennis Court

3G Fitness Park

Pool Massage
Beds





Sky
PARK
RESIDENCES

A WELCOMING LANDMARK

Where every day is a grand arrival

The entrance, with its distinctive welcoming arch and circular water feature, makes every step into and out of home a moment to be remembered. An artistic blend of curves and textures, this signature porch is an architectural statement as much as an all-weather shelter.

AT HOME WITH SKY-HIGH LIFESTYLES



N SKYPARK
0 5 10 15 METERS

Artist's Impression

- | | | | |
|---------------------|--------------------------|--------------------------|-------------------|
| 1. Starlight Dining | 4. Children's Playground | 7. 3G Sky Fitness | 10. Sky Pavilion |
| 2. Sky Lounge | 5. Pebble Walk | 8. SkyPark Jogging Track | 11. Moon Pavilion |
| 3. Outdoor Living | 6. Star Gazing Lawn | 9. Moonlight Creek | 12. Sun Pavilion |

Where you feel on top of the world

The first executive condominium to feature a SkyPark, 15 storeys high up in the atmosphere. A sprawling 1,250 square metres brimming with recreational and lifestyle facilities; take a run along the 200-metre SkyPark Jogging Track, throw a family party at the Sky Lounge, or kick back and stargaze.

GET HIGH ON GREAT VIEWS



Where stars twinkle and clouds flutter

At 44 metres above ground, enjoy the spectacular panorama of green expanses and the whole of Sembawang fanned out in sunset hues. Under the starry skies, or in a magical sunrise moment, take in the most privileged views of Singapore's northern skylines.

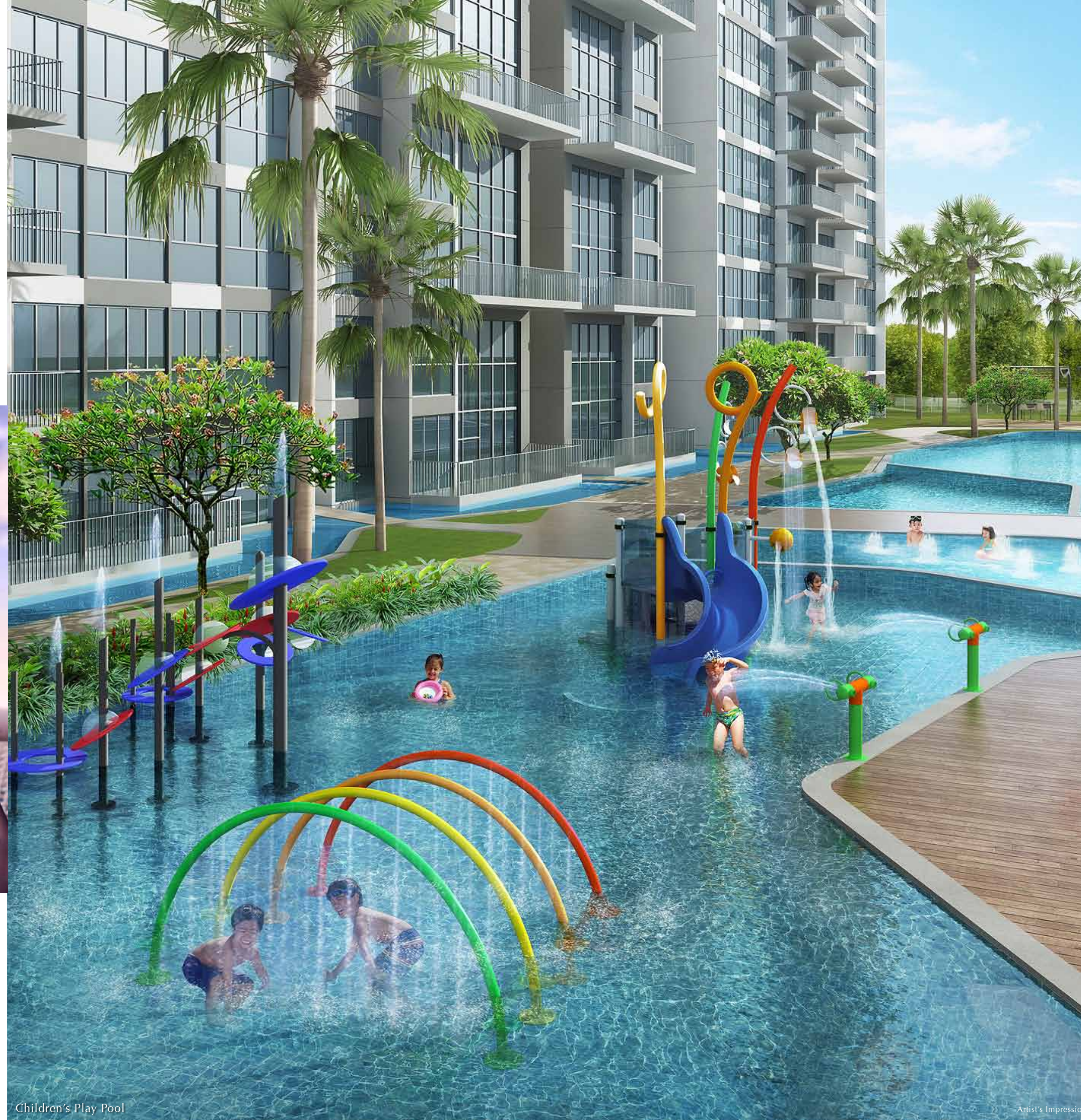

Children's Play Pool

Artist's Impression

HOME IS A WATER PARADISE



Jacuzzi

Where there are pools, spas and gallons more

Be showered with a wide array of water-themed facilities. Enjoy a morning swim in the 50-Metre Lap Pool; dunk your children in the Children's Play Pool. Or indulge in aquatic wellness with the Pool Massage Beds and Jacuzzi. Every day can be drenched in water fun.

A HUB OF FUN AND MORE



Function Room



Gymnasium

Where it houses fulfilling lifestyles

The pool-side Clubhouse features two storeys of lifestyle options. From a well-equipped gymnasium to a stately function room, the Clubhouse is designed with an open rooftop lounge that overlooks the sparkling 50-Metre Lap Pool. For a memorable dining experience, huddle within the Pool Dining Pods.

Site Plan

SEMBAWANG DRIVE

SEMBAWANG CRESCENT

SEMBAWANG AVENUE

ENTRANCE

1. Side Gate
2. Guardhouse
3. Jet Fountain
4. Arrival Court
5. Residents' Entrance

WELLNESS

6. Cascade Stream
7. Meditation Garden
8. Tai Chi Courtyard
9. Zen Garden
10. Sun Deck
11. Sparkling Brooks
12. Palm Garden
13. Sensory Garden
14. 3G Fitness Park
15. Tennis Court
16. Jogging Track
17. Yoga Deck

AQUATIC

18. Children's Play Pool
19. Wading Pool
20. Children's Spa Pool
21. Jacuzzi
22. Lounge Pool
23. Spa Beds
24. 50m Lap Pool
25. Aqua Lounge

MERRIMENT

26. Teahouse Pavilion
27. Children's Play Deck
28. Barbecue Pavilions
29. Picnic Lawn
30. Pool Dining Pods
31. Clubhouse
32. Pool Pavilions
33. Alfresco Dining Canopies
34. Children's Playground
35. Games Pavilion



Specially tailored for
your dwelling needs

5-bedroom
Maisonette

5-bedroom

4-bedroom

3-bedroom



LIVE WITHIN DOUBLE-STOREY GRANDEUR



Where loft homes are within reach

Featuring double-volume ceiling space in living and dining rooms, the maisonettes are specially designed for multi-generational living and those who desire the luxury of space. With regular configurations and maximum floor-to-ceiling heights, this is loft living at its best.

DRAFT

www.8yolkdesignstudio.com

8YOLK DESIGN STUDIO

Artist's Impression



ALWAYS ROOM FOR DETAILS

Showflat Photo

Where every waking moment is a joy

Characterised by functional layouts, a generous distance between towers and pool views most units, the bedrooms will provide maximum dwelling comfort and a good night's rest. And there is always room to transform them into your personalised domain.



Artist's Impression

Unit Distribution

Tower A

UNIT LEVEL	4	1	2	3
16		PH8	PH4	
15	C1	C1	C2	C2
14	C1	C1	C2	C2
13	C1	C1	C2	C2
12	C1	C1	C2	C2
11	C1	C1	C2	C2
10	C1	C1	C2	C2
9	C1	C1	C2	C2
8	C1	C1	C2	C2
7	C1	C1	C2	C2
6	C1	C1	C2	C2
5	C1	C1	C2	C2
4	C1	C1	C2	C2
3	C1	C1	C2	C2
2	C1	C1	C2	C2
1	C1P2	C1P1	C2P2	C2P3

Tower B

UNIT LEVEL	6	7	8	5
16		PH3	PH8	
15	D2	D1	C1	C1
14	D2	D1	C1	C1
13	D2	D1	C1	C1
12	D2	D1	C1	C1
11	D2	D1	C1	C1
10	D2	D1	C1	C1
9	D2	D1	C1	C1
8	D2	D1	C1	C1
7	D2	D1	C1	C1
6	D2	D1	C1	C1
5	D2	D1	C1	C1
4	D2	D1	C1	C1
3	D2	D1	C1	C1
2	D2	D1	C1	C1
1	D2P	D1P	C1P1	C1P1

Tower C

UNIT LEVEL	27	28	29	30	31	32	25	26
16		PH2				PH1b		PH1a
15	B1a	A1	A1	B2	B3b	A2	A2	B3a
14	B1a	A1	A1	B2	B3b	A2	A2	B3a
13	B1a	A1	A1	B2	B3b	A2	A2	B3a
12	B1a	A1	A1	B2	B3b	A2	A2	B3a
11	B1a	A1	A1	B2	B3b	A2	A2	B3a
10	B1a	A1	A1	B2	B3b	A2	A2	B3a
9	B1a	A1	A1	B2	B3b	A2	A2	B3a
8	B1a	A1	A1	B2	B3b	A2	A2	B3a
7	B1a	A1	A1	B2	B3b	A2	A2	B3a
6	B1a	A1	A1	B2	B3b	A2	A2	B3a
5	B1a	A1	A1	B2	B3b	A2	A2	B3a
4	B1a	A1	A1	B2	B3b	A2	A2	B3a
3	B1a	A1	A1	B2	B3b	A2	A2	B3a
2	B1a	A1	A1	B2	B3b	A2	A2	B3a
1	B1aP	A1P	A1P	B2P1	B3bP	A2P	A2P	B3aP1

Legend

- 3-bedroom
- 3-bedroom + study
- 4-bedroom
- 4-bedroom + study
- 5-bedroom
- 5-bedroom Maisonette

Floor Plans

3-bedroom

Type A1

106 sq m / 1141 sq ft
 #02-02 to #15-02
 #02-06 to #15-06
 #02-10 to #15-10
 #02-14 to #15-14
 #02-15 to #15-15

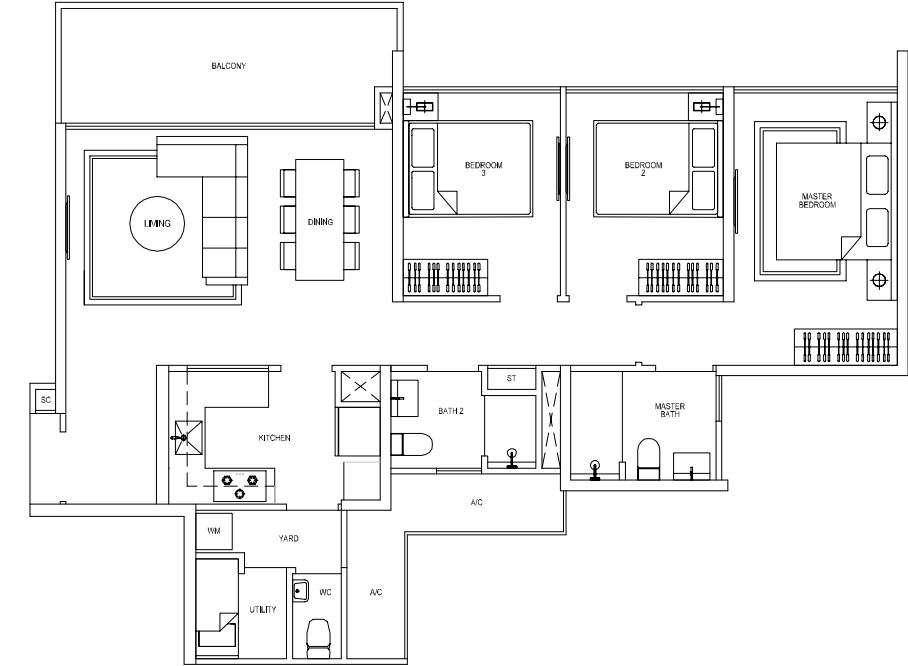

Type A1a (Partial plan)

106 sq m / 1141 sq ft
 #01-02
 #01-10
 #01-14
 #01-15

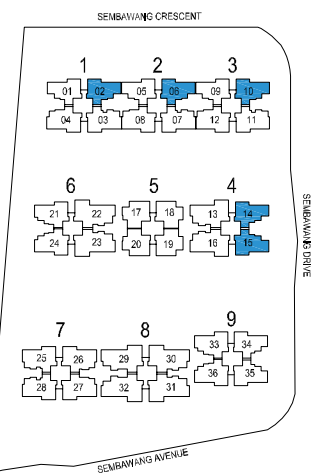
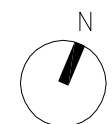
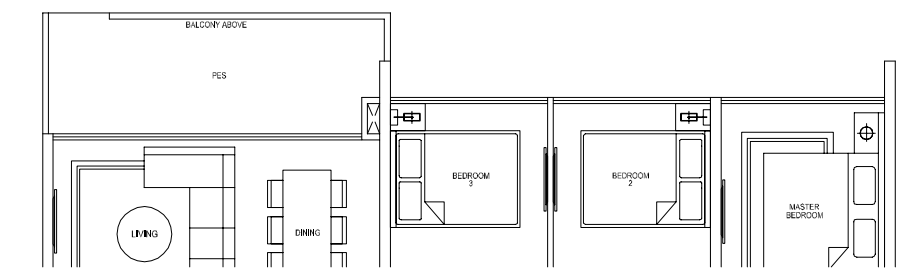

Key plan (Not to scale)

Areas include A/C ledge, balcony and PES. Orientations and facings will differ depending on the unit you are purchasing. Please refer to the key plan. The plans are subjected to change as may be required or approved by relevant authorities. All areas are approximate and subject to final survey. The developer and its agents cannot be held liable for any inaccuracies.

Floor Plans

3-bedroom

Type A2

107 sq m / 1152 sq ft
 #02-01 to #15-01
 #02-05 to #15-05
 #02-09 to #15-09
 #02-34 to #15-34
 #02-35 to #15-35

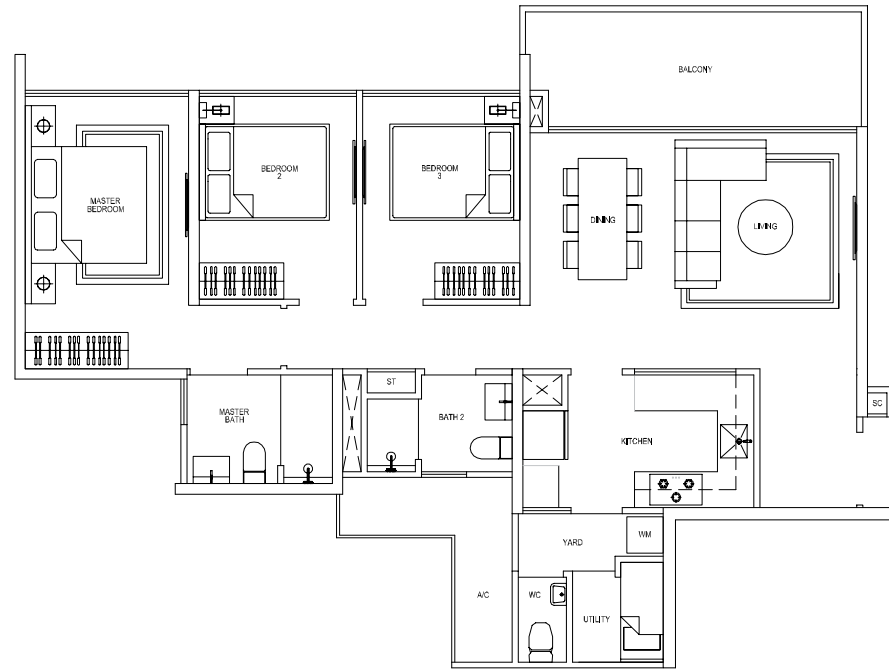

Type A2a (Partial plan)

107 sq m / 1152 sq ft
 #01-01
 #01-09
 #01-34
 #01-35

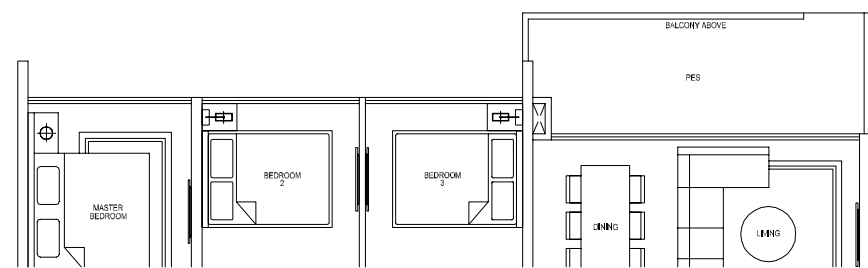

Areas include A/C ledge, balcony and PES. Orientations and facings will differ depending on the unit you are purchasing. Please refer to the key plan. The plans are subjected to change as may be required or approved by relevant authorities. All areas are approximate and subject to final survey. The developer and its agents cannot be held liable for any inaccuracies.

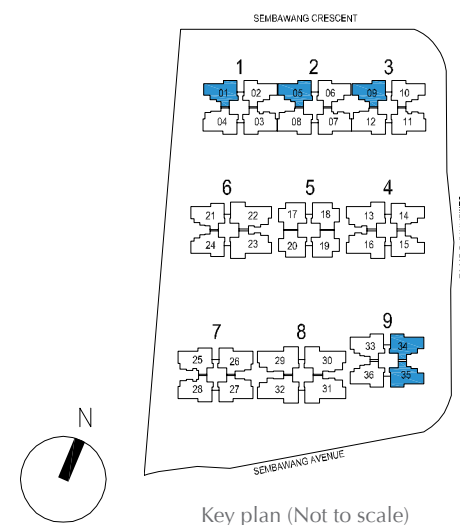

Floor Plans

3-bedroom + study

Type B1

115 sq m / 1238 sq ft
 #02-21 to #15-21
 #02-24 to #15-24
 #02-33 to #15-33
 #02-36 to #15-36

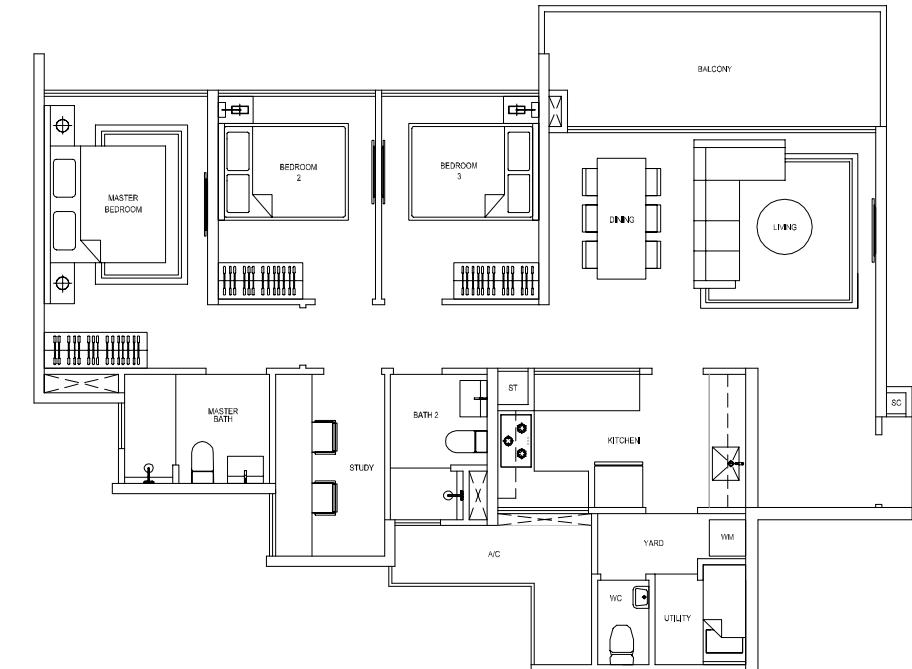

Type B1a (Partial plan)

115 sq m / 1238 sq ft
 #01-21
 #01-24
 #01-33
 #01-36

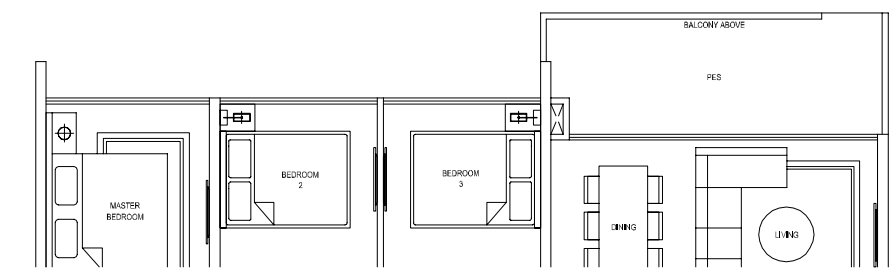

Areas include A/C ledge, balcony and PES. Orientations and facings will differ depending on the unit you are purchasing. Please refer to the key plan. The plans are subjected to change as may be required or approved by relevant authorities. All areas are approximate and subject to final survey. The developer and its agents cannot be held liable for any inaccuracies.

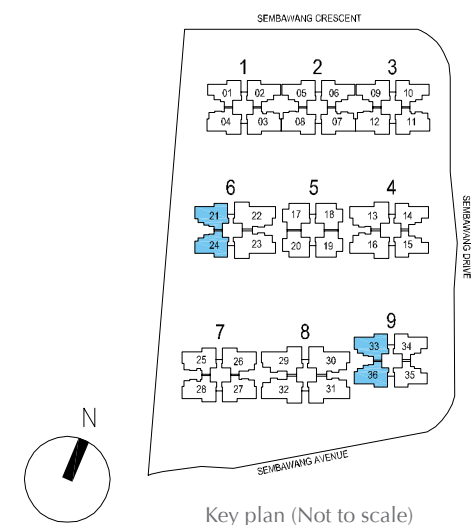

Floor Plans

4-bedroom

Type C1

121 sq m / 1302 sq ft
 #02-03 to #15-03
 #02-07 to #15-07
 #02-11 to #15-11
 #02-25 to #15-25
 #02-28 to #15-28



Type C1a (Partial plan)

125 sq m / 1346 sq ft
 #01-03
 #01-07
 #01-11
 #01-25

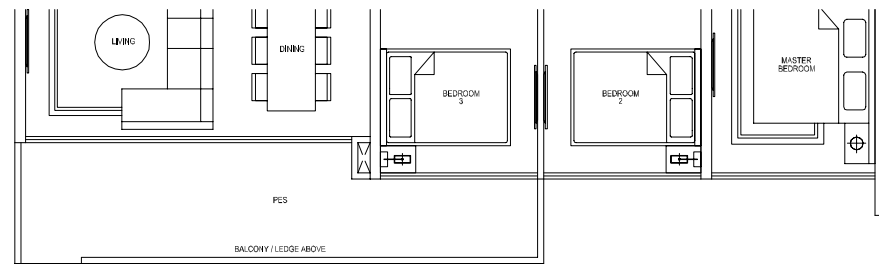

Type C1b (Partial plan)

121 sq m / 1302 sq ft
 #01-28

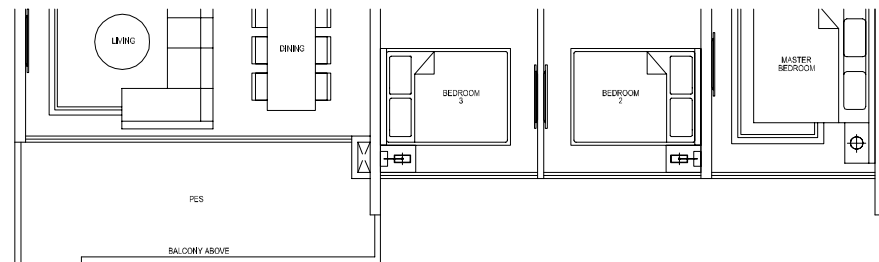

Areas include A/C ledge, balcony and PES. Orientations and facings will differ depending on the unit you are purchasing. Please refer to the key plan. The plans are subjected to change as may be required or approved by relevant authorities. All areas are approximate and subject to final survey. The developer and its agents cannot be held liable for any inaccuracies.

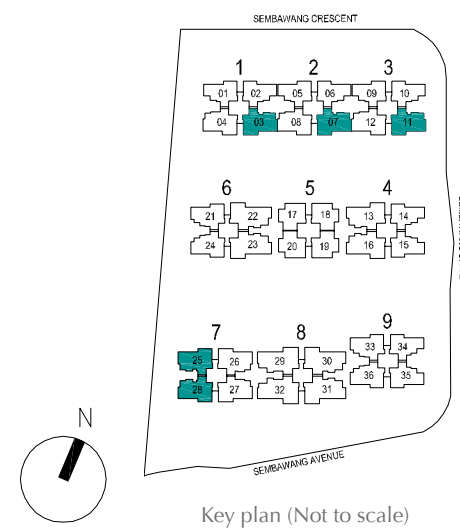

Floor Plans

4-bedroom

Type C2

122 sq m / 1313 sq ft
 #02-04 to #15-04
 #02-08 to #15-08
 #02-12 to #15-12
 #02-26 to #15-26
 #02-27 to #15-27

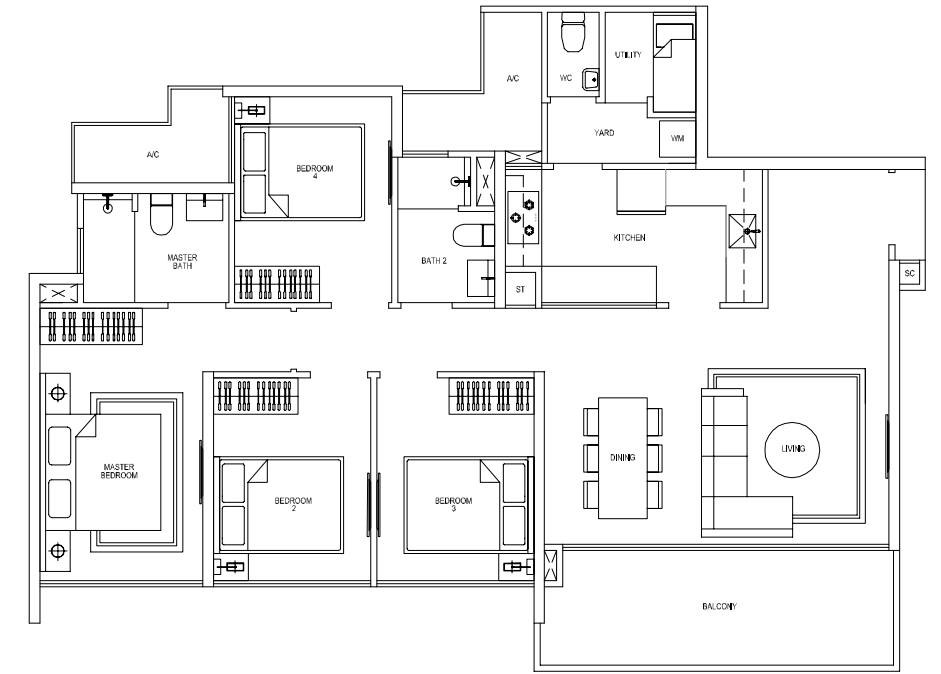

Type C2a (Partial plan)

126 sq m / 1356 sq ft
 #01-04
 #01-08
 #01-12
 #01-26

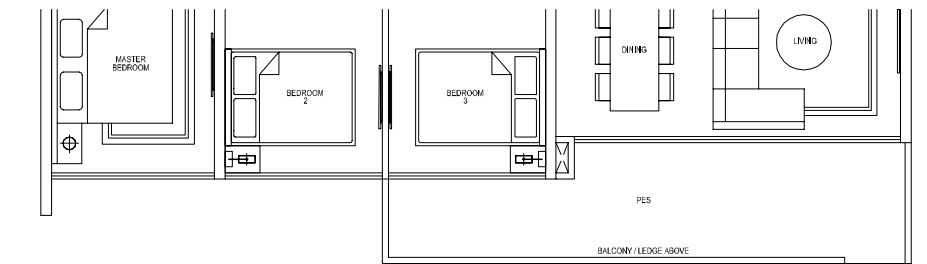

Type C2b (Partial plan)

122 sq m / 1313 sq ft
 #01-27

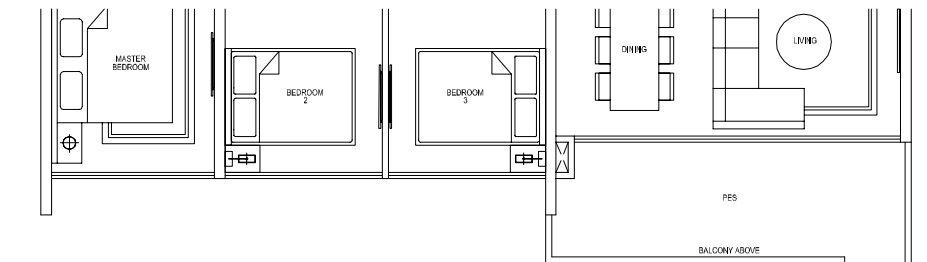

Areas include A/C ledge, balcony and PES. Orientations and facings will differ depending on the unit you are purchasing. Please refer to the key plan. The plans are subjected to change as may be required or approved by relevant authorities. All areas are approximate and subject to final survey. The developer and its agents cannot be held liable for any inaccuracies.

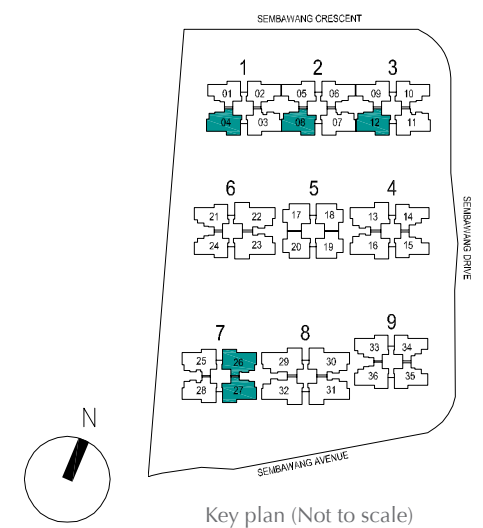

Floor Plans

4-bedroom + study

Type D1

142 sq m / 1528 sq ft
 #02-13 to #15-13
 #02-16 to #15-16



Type D1a (Partial plan)

147 sq m / 1582 sq ft
 #01-13
 #01-16

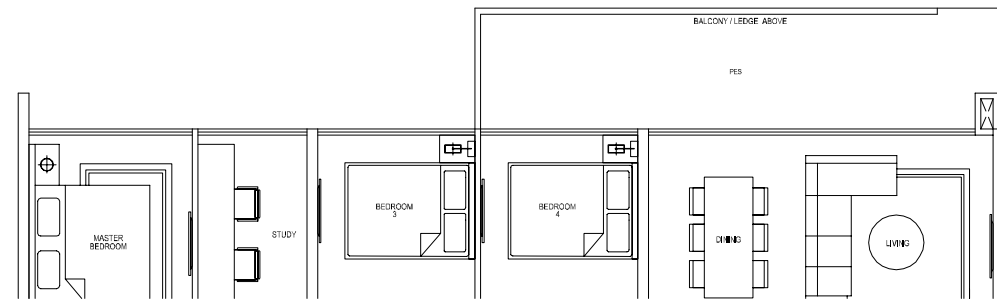

Areas include A/C ledge, balcony and PES. Orientations and facings will differ depending on the unit you are purchasing. Please refer to the key plan. The plans are subjected to change as may be required or approved by relevant authorities. All areas are approximate and subject to final survey. The developer and its agents cannot be held liable for any inaccuracies.

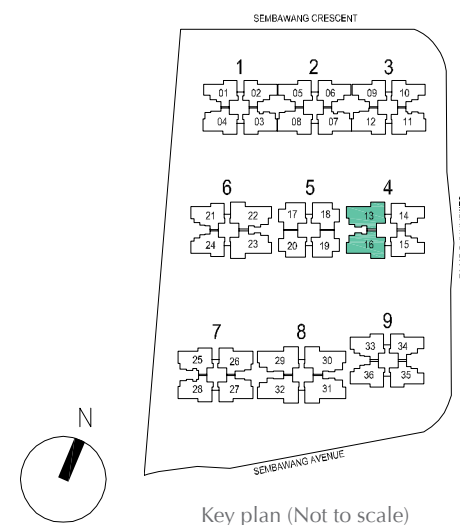

Floor Plans

5-bedroom

Type E1

148 sq m / 1593 sq ft
 #02-22 to #15-22
 #02-23 to #15-23
 #02-30 to #15-30
 #02-31 to #15-31

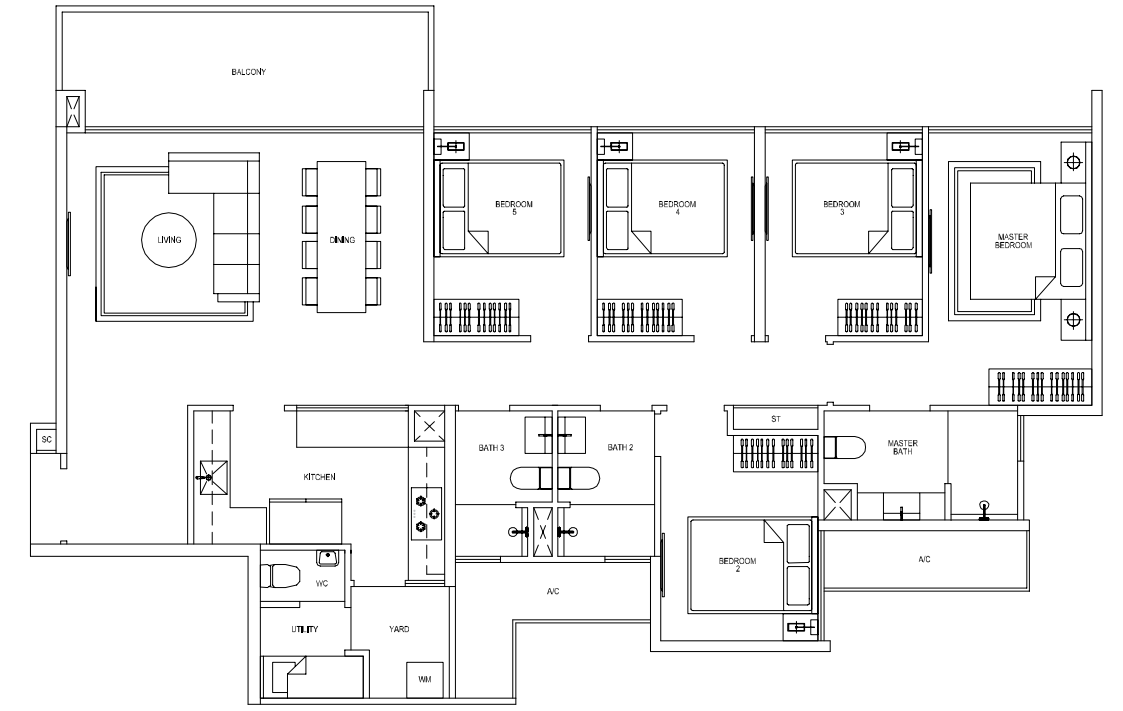

Type E1a (Partial plan)

159 sq m / 1711 sq ft
 #01-22
 #01-23
 #01-30

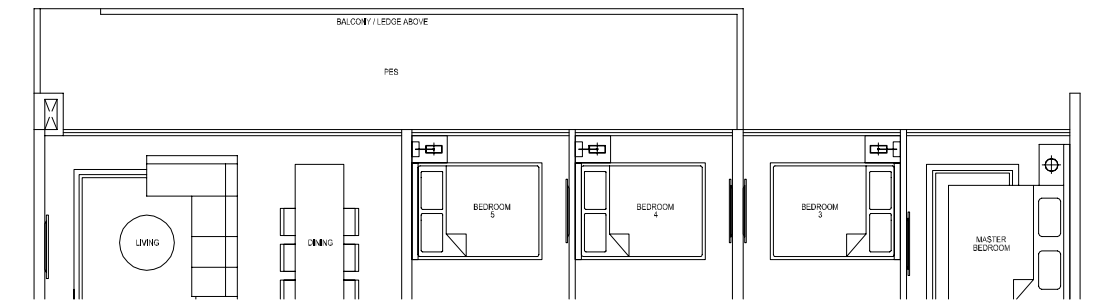

Type E1b (Partial plan)

154 sq m / 1658 sq ft
 #01-31

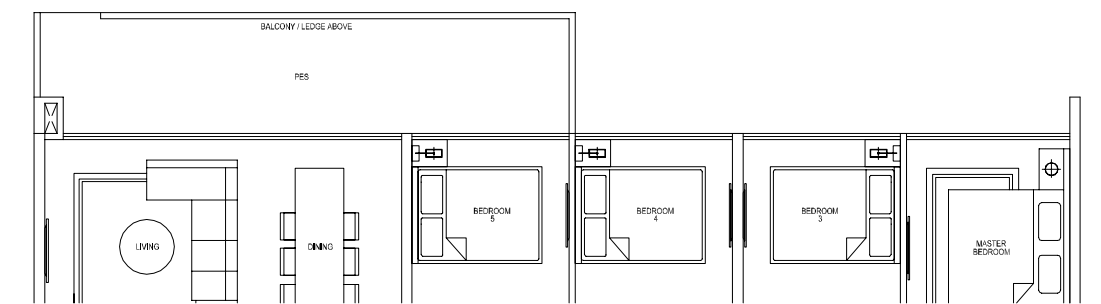

Areas include A/C ledge, balcony and PES. Orientations and facings will differ depending on the unit you are purchasing. Please refer to the key plan. The plans are subjected to change as may be required or approved by relevant authorities. All areas are approximate and subject to final survey. The developer and its agents cannot be held liable for any inaccuracies.

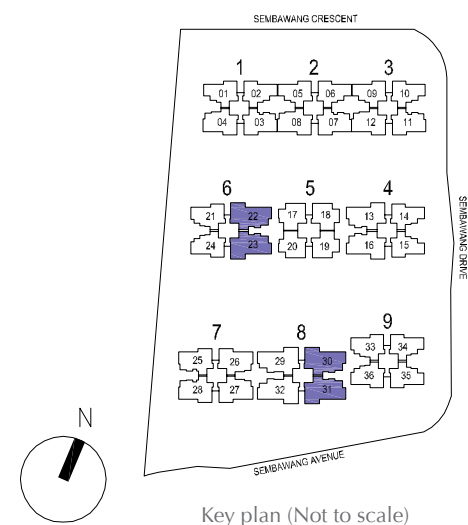

Floor Plans

5-bedroom

Type E2

148 sq m / 1593 sq ft
 #02-29 to #15-29
 #02-32 to #15-32



Type E2a (Partial plan)

159 sq m / 1711 sq ft
 #01-29

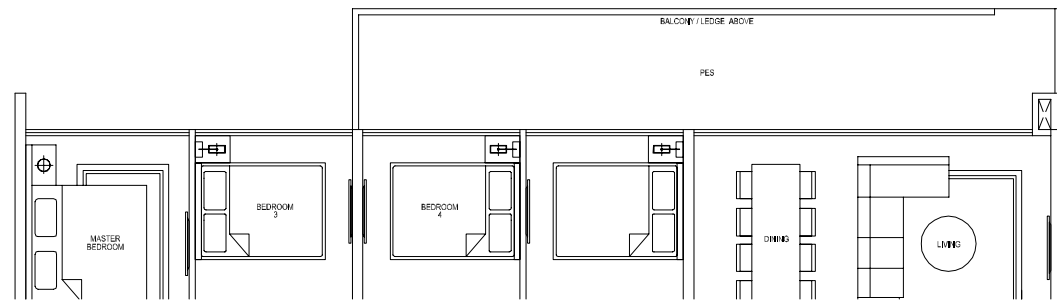

Type E2b (Partial plan)

153 sq m / 1647 sq ft
 #01-32

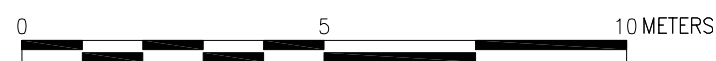
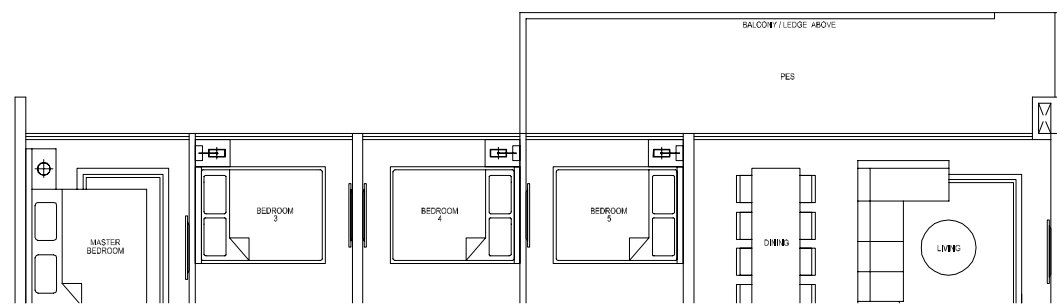

Areas include A/C ledge, balcony and PES. Orientations and facings will differ depending on the unit you are purchasing. Please refer to the key plan. The plans are subjected to change as may be required or approved by relevant authorities. All areas are approximate and subject to final survey. The developer and its agents cannot be held liable for any inaccuracies.

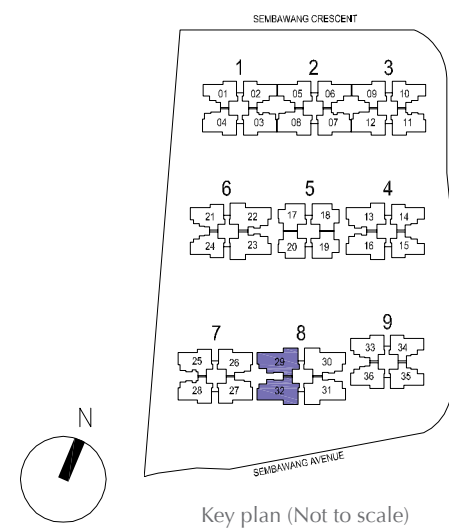

Key plan (Not to scale)

Floor Plans

5-bedroom Maisonette

Type F1

160 sq m / 1722 sq ft
 #02-17 to #07-17
 #02-18 to #07-18
 #02-19 to #07-19
 #02-20 to #07-20

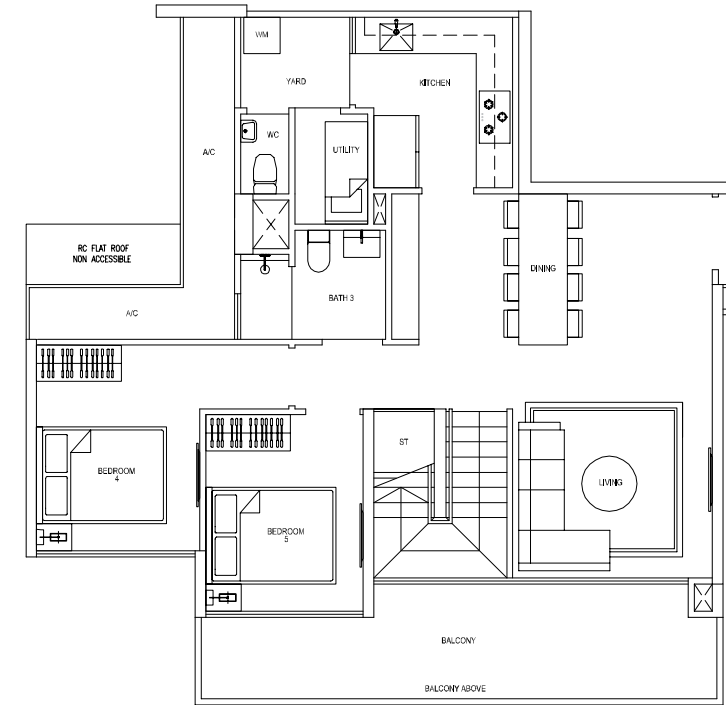

Lower

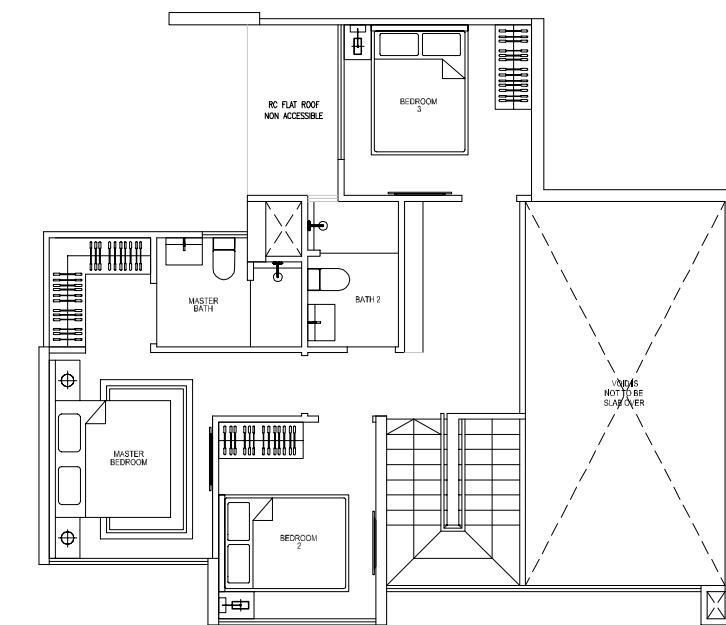

Upper



Areas include A/C ledge, balcony and PES. Orientations and facings will differ depending on the unit you are purchasing. Please refer to the key plan. The plans are subjected to change as may be required or approved by relevant authorities. All areas are approximate and subject to final survey. The developer and its agents cannot be held liable for any inaccuracies.

Type F1a (Partial plan)

160 sq m / 1722 sq ft
 #01-17
 #01-18
 #01-19
 #01-20

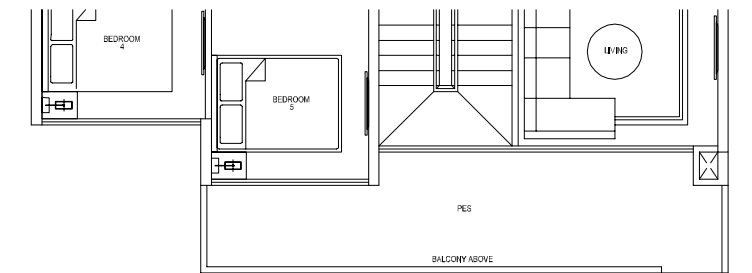

Lower

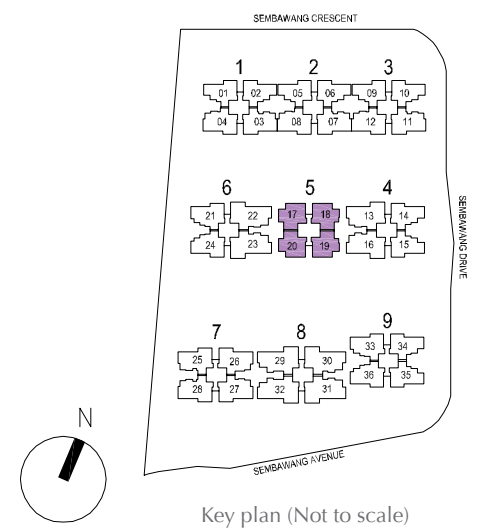

Key plan (Not to scale)

Specifications

- Foundation**
Piled Foundation
- Superstructure**
Cast in-situ and/or precast reinforced concrete and/or steel structure

- Walls**
 - Internal Walls : Reinforced concrete wall and/or brickwall and/or blockwall and/or dry wall partition/light weight concrete panel
 - External Walls : Reinforced concrete wall and/or brickwall and/or blockwall

- Roof**
a Flat Roof: Reinforced concrete slab with insulation and waterproofing system

- Ceiling**
 - Units
 - Skim coat and/or bulkheads and/or ceiling boards with emulsion paint finish to Living, Dining, Bedrooms, Study, Foyer, Store, Shoe Cabinet, PES, Balcony, Staircases and other areas where appropriate
 - Ceiling boards with emulsion paint to Bathrooms, Kitchen, Yard, Utility and WC
 - Common Areas
 - Skim coat and/or ceiling board and/ or bulkheads with emulsion paint finish to Lift Lobby
 - Skim coat with emulsion paint finish to Car Parks, Staircases and Storey Shelters

- Finishes**
 - Units
 - Walls
 - Plaster and/or skim coat with emulsion paint finish to Living, Dining, Bedrooms, Study, Foyer, Store, Shoe Cabinet, Yard, Utility, HS, PES, Balcony and Staircase
 - Tiles to Bathrooms and WC
 - Tiles and/or plaster and/or skim coat with emulsion paint finish to Kitchen

Note: No tiles behind kitchen cabinets, long bath, mirrors, vanity cabinets. Tiles are laid up to false ceiling and on exposed areas only.

- Floor
 - Tiles to Living, Dining, Kitchen, Bathrooms, Foyer, Store, Shoe Cabinet, WC, Utility, Yard, HS, PES and Balcony
 - Timber to Bedrooms, Study and Staircase
- Common Areas
 - Internal Walls
 - Tiles and/or plaster and/or skim coat with emulsion paint finish to Lift Lobbies and Club House
 - Plaster and/or skim coat with emulsion paint finish to Common Corridors, Staircases, Storey Shelters, Car Parks and Ramps
 - External Walls
 - Plaster and/or skim coat with spray textured coating and/or emulsion paint finish
 - Internal Floors
 - Tiles to Lift Lobbies and Club House
 - Cement sand screed to Staircases and Storey Shelter
 - Concrete floor with hardener to Car Parks and Ramps
 - External Floors
 - Tiles and/or Pebble Wash to Walkway
 - Mosaics and/or Tiles to Pools
 - Tiles and/or Pebble Wash and/or timber deck to Decks

- Windows**
All windows of the unit will be powder coated aluminium framed windows

- Doors**
 - Timber door to Main Entrance, Bedrooms, Study (where applicable) and Bathrooms
 - Timber door to Store and Shoe Cabinet
 - Timber framed glass door to Kitchen
 - PVC folding door to WC and Utility
 - Aluminium framed glass door and/or fixed glass panel to PES and Balcony
 - Good quality locksets for doors where applicable

- Sanitary Fittings**
 - Bathroom
 - Wash basin & mixer tap with cabinet
 - Shower compartment complete with 1 shower mixer
 - Pedestal water closet
 - Mirror
 - Toilet paper holder
 - Towel rail

- WC
 - Wash basin & tap
 - Shower set
 - Pedestal water closet
 - Toilet paper holder
- Yard
 - Washing machine bib tap
 - PES
 - Bib tap

- Electrical Schedule**
Refer to Electrical Schedule for details

- Cable TV/ Telephone Schedule**
Refer to Electrical Schedule for details

- Lightning Protection**
Lightning protection system will be provided in accordance with Singapore Standard.

- Painting**
See Items 6(i)(a), 6(ii)(a) and 6(ii)(b)

- Waterproofing**
Waterproofing is provided to floors of Baths, Kitchen, Yard, WC, PES, Balcony and areas where appropriate

- Driveway and Car park**
 - Pavers to surface driveway and drop-off
 - Concrete floor finish with hardener to car park, ramps and driveway

- Recreational Facilities**
ENTRANCE
 - Side Gate
 - Guardhouse
 - Jet Fountain
 - Arrival Court
 - Residents’ EntranceWELLNESS
 - Cascade Stream
 - Meditation Garden
 - Tai Chi Courtyard
 - Zen Garden
 - Sun Deck
 - Sparkling Brooks
 - Palm Garden
 - Sensory Garden
 - 3G Fitness Park
 - Tennis Court
 - Jogging Track
 - Yoga Deck

- AQUATIC
 - Children’s Play Pool
 - Wading Pool
 - Children’s Spa Pool
 - Jacuzzi
 - Lounge Pool
 - Spa Beds
 - 50m Lap Pool
 - Aqua LoungeMERRIMENT
 - Teahouse Pavilion
 - Children’s Play Deck
 - Barbecue Pavilions
 - Picnic Lawn
 - Pool Dining Pods
 - Clubhouse
 - Pool Pavilions
 - Alfresco Dining Canopies
 - Children’s Playground
 - Games Pavilion

- SKYPARK
 - Starlight Dining Terrace
 - Sky Lounge
 - Outdoor Living Court
 - Children’s Playground
 - Pebble Walk
 - Star Gazing Lawn
 - 3G Sky Fitness
 - SkyPark Jogging Track
 - Moonlight Creek
 - Sky Pavilion
 - Moon Pavilion
 - Sun Pavilion

- Additional Items**
 - Kitchen Cabinets and appliances:
 - Low and high level kitchen cabinets with solid surface worktop and stainless steel sink
 - Cooker hood

- Gas cooker hob
- Built-in oven
- Wardrobes : Wardrobes to all Bedrooms
- Air-conditioning Living, Dining, Bedrooms and Study: Wall mounted fan coil unit
- Hot Water Supply : Hot water supply to all Bathrooms except WC. All units will be provided with gas water heater.
- Gas : Town Gas supply to Kitchen and hot water heaters (Turn-on and utility charges will be borne by the Purchaser)
- Metal Railing : Metal railing for PES and Balcony
- Cable Television : Provision of cable outlet only for cable television services. Subscription charges shall be borne by Purchaser
- Security System :
 - Card Access System
 - Designated Lift Cars
 - Pedestrian side gate/s
 - Clubhouse, gymnasium
 - Audio intercom system to Units
 - Car park barrier system and/or gate at Main & Side Entrance
 - CCTV surveillance cameras at designated common areas.
- Fiber Broadband : Provision of infrastructure for Open Net to lay fiber into unit and 1 no. CAT 6 data point provided within the unit for Next Generation Nationwide Broadband Network (Next Gen NBN). Subscription charges to Open Net shall be borne by the Purchaser

Notes:

Marble, Limestone and Granite

Marble, limestone and granite are natural stone materials containing veins with tonality differences. There will be colour and markings caused by their complex mineral composition and incorporated impurities. While such materials can be pre-selected before installation, this non-conformity in the marble, limestone or granite as well as non-uniformity between pieces cannot be totally avoided. Granite tiles are pre-polished before laying and care has been taken for their installation. However granite, being a much harder material than marble cannot be re-polished after installation. Hence some differences may be felt at the joints. The tonality and pattern of the marble, limestone or granite selected and installed shall be subject to availability.

Cable Television and/or Internet Access

The Purchaser is liable to pay annual fee, subscription fee and such other fees to the Starhub Cable Vision Ltd (SCV) and/or internet service providers (ISP) or any other relevant party or any other relevant authorities. The Vendor is not responsible to make arrangements with any of the said parties for the service connection for their respective subscription channels and/or internet access.

Timber

Timber is a natural material containing grain/vein and tonal differences. Thus it is not possible to achieve total consistency of colour and grain in its selection and installation.

Glass

Glass is widely used in residential developments and my break/shatter due to accidental knocks or other causes. In addition, glass is a manufactured material that may not be 100% free from impurities. These impurities may on rare occasions cause spontaneous glass breakage in certain pieces of tempered glass that may be used where applicable. It is difficult to detect these impurities, which may be present in tempered glass. The purchaser is recommended to take up home insurance covering glass breakage to cover this possible event.

Tiles

All tiles, plaster, skim coat and emulsion paint are provided up to false ceiling level and on exposed surfaces only. No tiles behind/ below kitchen cabinet, vanity cabinet and areas enclosed by long bath and at back and plinth of kitchen cabinet. Wall surface above the false ceiling level will be left in its original bare condition. Selected tile sizes and tile surface flatness cannot be perfect, and are subject to acceptable range described in the relevant Singapore Standards.

Specifications

False Ceiling

The space provision allows for the optimal function and installation of M&E services. Access panels are allocated for ease of maintenance access to concealed M&E equipment for regular cleaning purposes. Where removal of equipment is needed, ceiling works would be required.

- Balconies, PES and Reinforced Concrete (RC) Ledge and Reinforced Concrete (RC) and/or Steel Trellis**
Where the Building is designed with a Balcony, PES, RC Ledge, RC and/or Steel Trellis or which are open or covered by roofings, the Purchaser shall not dismantle such roofings nor shall the Purchaser cover up or erect any roof structure (including but not limited to retractable awnings) over such Balcony and/or PES and/or RC Ledge and/or RC and/or Steel Trellis except with the prior approval in writing of the relevant competent authorities and the Vendor.

ELECTRICAL SCHEDULE

Description	3-BEDROOM	3-BEDROOM PREMIUM	4-BEDROOM	4-BEDROOM PREMIUM	5-BEDROOM	5-BEDROOM MAISONETTE
LIGHTING POINT	13	14	14	16	16	21
13A SSO	23	25	27	29	31	31
WATER HEATER POINT	1	1	1	1	1	1
DATA OUTLET	2	2	2	2	2	2
SCV OUTLET	4	5	5	6	6	6
TELEPHONE OUTLET	4	5	5	6	6	6
CONNECTION UNIT FOR HOOD, HOB, OVEN	3	3	3	3	3	3
INTERCOM POINT	1	1	1	1	1	1
BELL POINT	1	1	1	1	1	1
ISOLATOR	According to the no. of Condenser Unit for each unit					

Wardrobes, Kitchen Cabinets, Fan Coil Units, Gas Pipes and Heaters, Electrical Points, Door Swing Positions and Plaster Ceiling Boards

Layout/Location of wardrobes, kitchen cabinets, fan coil units, gas pipe and heaters, electrical points, door swing positions and plaster ceiling boards are subject to Architect’s sole discretion and final design.

Materials, Fittings, Equipment, Finishes, Installations and Appliances

The brand, colour and model of all materials, fittings equipments, finishes, installations and appliances supplied shall be subjected to Architect’s selection, market availability and the sole discretion of the vendor.

Air-Conditioning System

To ensure good working condition of the air-conditioning system, the system has to be maintained and cleaned by the Purchaser on a regular basis. This includes the cleaning of filters, clearing the condensate pipes and charging of gas.

Web Portal of the Housing Project

The Purchaser will have to pay setup fee, annual fee, subscription fee or any such fee to the service provider of the Web Portal of the Housing Project as may be appointed by the Vendor or the Management Corporation when it is formed.

Internet Access

If the Purchaser requires internet access, the Purchaser will have to make direct arrangements with the Internet Service Provider and/or such relevant entities/authorities for internet services to the Unit and to make all necessary payments to the Internet Service Provider and/or the relevant entities/authorities.

Warranties

Where warranties are given by the manufacturers and/ or contractors and/or suppliers of any of the equipment and/or appliances installed by the Vendor at the Unit, the Vendor shall assign to the Purchaser such warranties at the time when possession of the Unit is delivered to the Purchaser.

Lorem ipsum dolor sit amet, consectetur adipiscing elit, sed diam nonummy nibh euismod tincidunt ut laoreet dolore magna aliquam erat volutpat. Duis aut riure dolor in hendrerit in vulputate velit esse molestie consequat, vel illum dolore eu feugiat nulla

Developers



JBE Holdings Pte Ltd

JBE Holdings Pte Ltd (“JBE Holdings”) is a property developer with a strong commitment to environmental sustainability and enriching lives through thoughtful and quality home concepts.

With a diverse track record that spans residential and mixed-use projects, JBE Holdings has developed Luxe Ville, a freehold 50-unit condominium at Pasir Panjang Road; and 53 units of terrace houses at Sembawang Greenvale next to Sembawang Park.

JBE Holdings is also the owner and developer of The Luxe, a mixed-use development at Handy Road in the heart of Orchard area. The development concept of The Luxe is to enable city living amid artistic ambiance in Singapore’s centrally-located art and heritage district.

SkyPark Residences marks JBE Holdings’ foray into the development of executive condominiums. The development vision of SkyPark Residences is to up the ante of executive condominium living through a luxurious SkyPark perched in the sky with a wide range of recreational and lifestyle facilities.

JBE Holdings is a private developer with a decade of development experience in Singapore.



The Luxe



Luxe Ville



53 units of terrace houses at Sembawang Greenvale



KEONG HONG

Keong Hong Holdings Limited

Keong Hong Holdings Limited (“Company”), our subsidiaries and our Associated Company (collectively referred to as the “Group”), was established in Singapore in 1983 and listed on the Catalist Board of the Singapore Exchange Securities Trading Limited (the “SGX-ST”) in 2011. The Group is a provider of a broad range of building construction services to both private and public sectors for residential, commercial, industrial and institutional projects.

Our Group’s business comprises building construction services including conventional contracts, additions and alterations (“A&A”) and Design & Build (“D&B”) projects in Singapore and the Maldives, and property development in Singapore.

With over 25 years of experience, the Group has established a strong customer base comprising major players in the construction industry. Our major customers include well-known property developers and owners such as Keppel Land group, Frasers Centrepoint Limited, MCL Land Ltd for private sector projects, as well as government bodies and statutory boards for public sector projects. Our diversified portfolio of projects includes The Esta, IBIS Hotel Project, Falhumaafushi Resorts, Maldives, Singapore Institute of Management, Sime Darby Performance Centre, The Belvedere, Martin Place Residences, Parvis @ Holland Hill and 8@Woodleigh Close. In 2011, we also forayed into property development through a joint venture with FCL Tampines Court Pte. Ltd. to develop a 728-unit executive condominium project in Punggol.



Twin Waterfalls

Led by a highly qualified and experienced management team with a total staff strength of over 100, Keong Hong has built a strong reputation in the market for its commitment to quality and service. The Group achieved numerous industry recognitions including BCA A1 grading under the category CW01 for general building which allows us to tender for public sector construction projects of unlimited value with no restrictions for private sector construction projects, as well as BCA Award for Construction Excellence. The Group was also awarded ISO 9001:2008 and SS ISO 9001:2008 Certificate of Registration (Quality Management System) for design management and building construction services, ISO 14001:2004 and SS ISO 14001:2004 Certificate of Registration (Environmental Management System) and OHSAS 18001:2007 Certificate of Registration (Occupational Health and Safety Management System).



The Parvis



8@Woodleigh

